

4

3

2

1

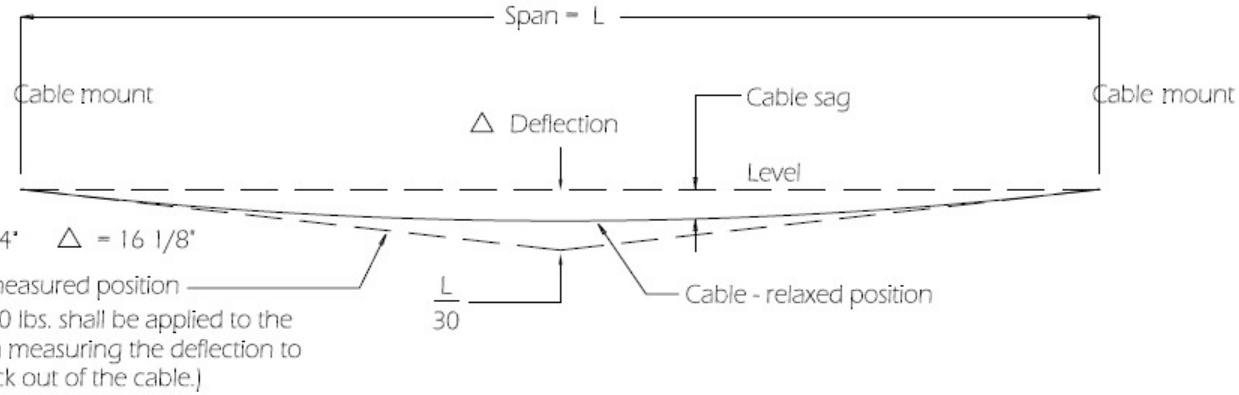

## HORIZONTAL LIFELINE INSTALLATION CRITERIA

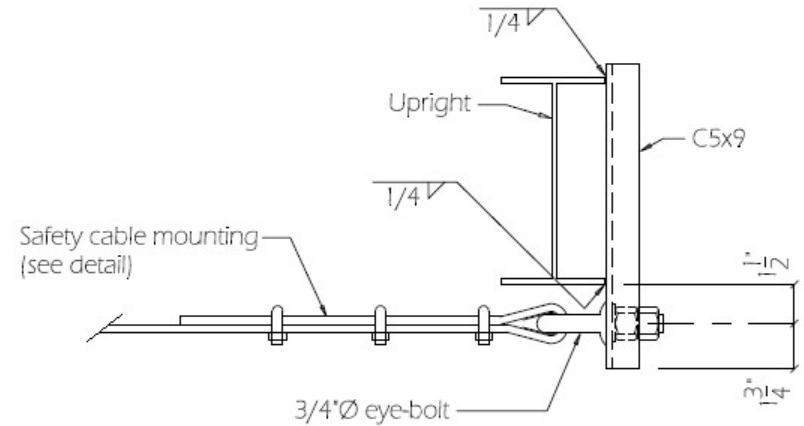
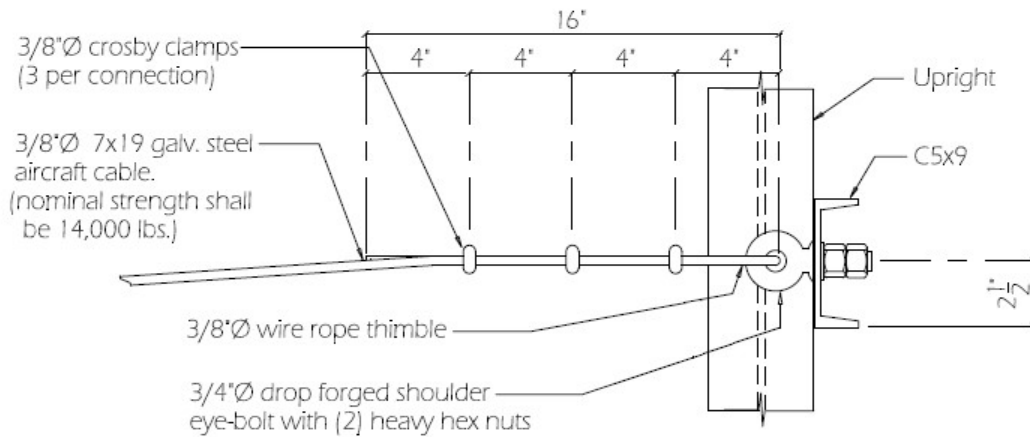

## TOP VIEW

## SAFETY CABLE MOUNTING

UNLESS OTHERWISE SPECIFIED  
DIMENSIONS ARE IN INCHES  
TOLERANCES  
FRACTIONAL  $\pm 1/16''$   
ANGULAR BEND  $\pm 2''$

**FORMETCO**<sup>®</sup>

2963 Pleasant Hill Road  
Duluth, GA 30096

PROPRIETARY AND CONFIDENTIAL THE INFORMATION CONTAINED IN THIS DRAWING IS THE SOLE PROPERTY OF FORMETCO. ANY REPRODUCTION IN PART OR AS A WHOLE WITHOUT THE WRITTEN PERMISSION OF FORMETCO IS PROHIBITED.	MATERIAL	VARIED	CREATED	BDJ	DATE	SIZE	DRAWING NUMBER SAFETY-CABLE	REVISION A
	MATERIAL FINISH	VARIED	7/12/2022 2:17:29 PM					
DO NOT SCALE DRAWING	UPDATED	Tuesday, July 12, 2022 3:07:48 PM				WEIGHT:	SHEET 1 OF 2	

4

3

2

1