

4

3

2

1

B

B

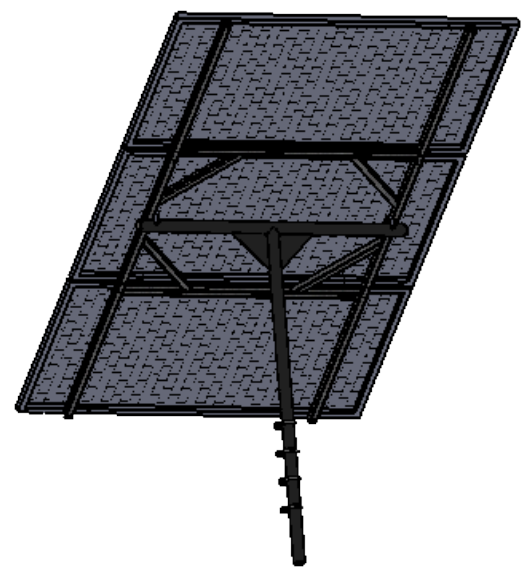
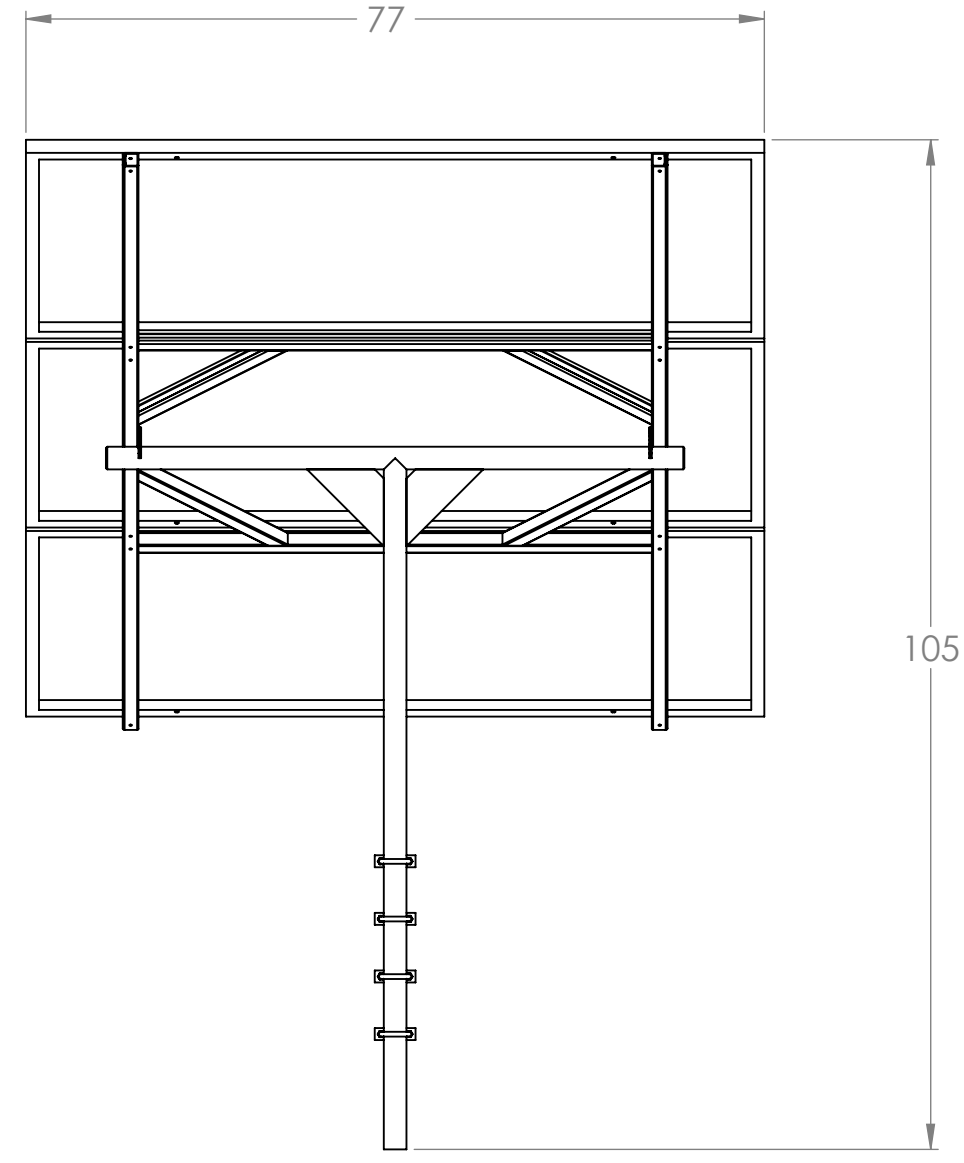
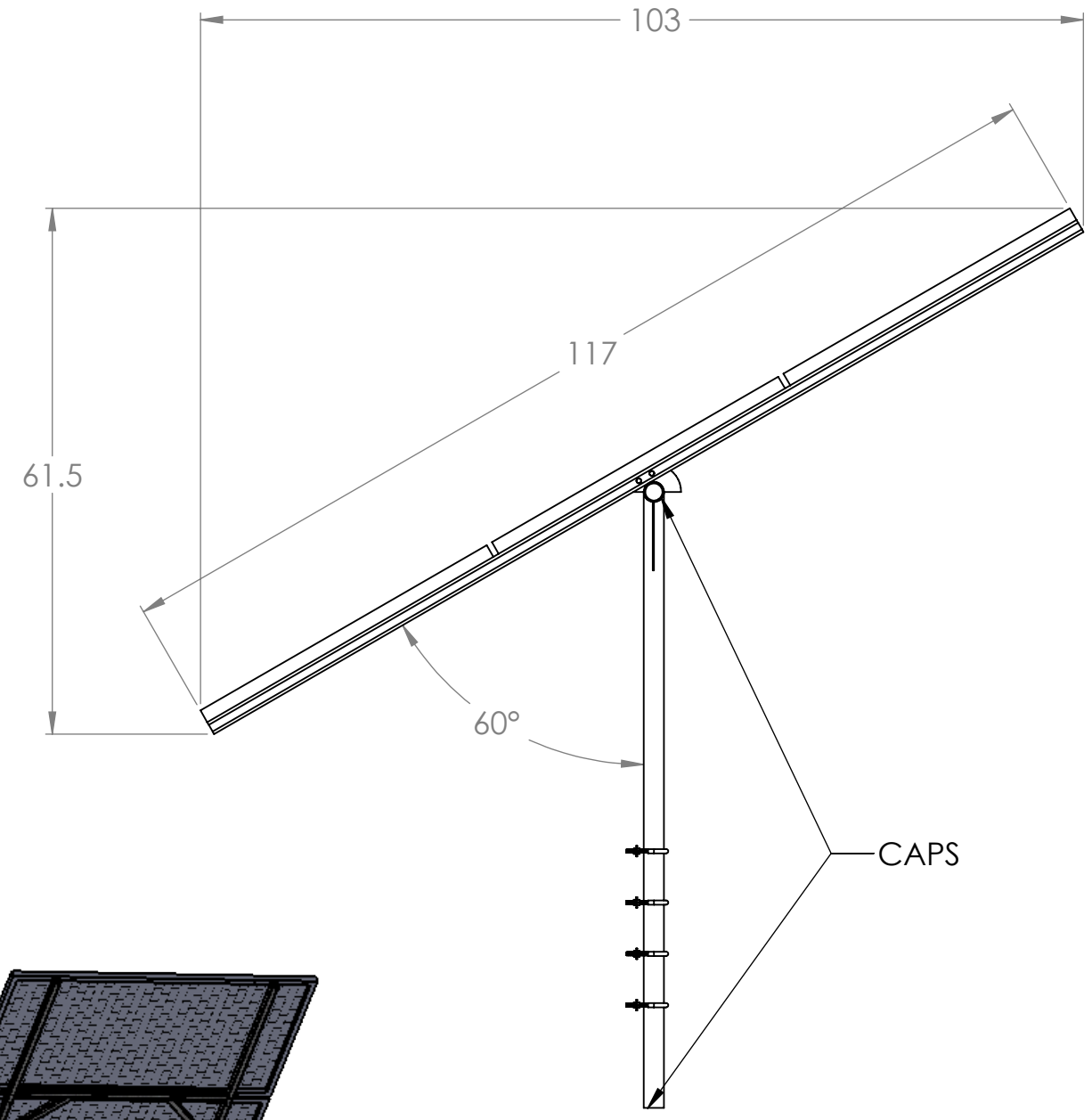

4

3

2

1

A

A

UNLESS OTHERWISE SPECIFIED

DIMENSIONS ARE IN INCHES
TOLERANCES
FRACTIONAL ± 1/16"
ANGULAR BEND ± 2°



2963 Pleasant Hill Road
Duluth, GA 30096

PROPRIETARY AND CONFIDENTIAL THE INFORMATION CONTAINED IN THIS DRAWING IS THE SOLE PROPERTY OF FORMETCO. ANY REPRODUCTION IN PART OR AS A WHOLE WITHOUT THE WRITTEN PERMISSION OF FORMETCO IS PROHIBITED.	MATERIAL VARIED	CREATED 7/18/2016 9:05:27 AM	BDJ	DATE	SIZE B	DRAWING NUMBER SOLAR-PANEL	REVISION A
	DO NOT SCALE DRAWING	UPDATED	Wednesday, March 08, 2017 10:30:59 AM		WEIGHT:	SHEET 1 OF 5	

4

3

2

1

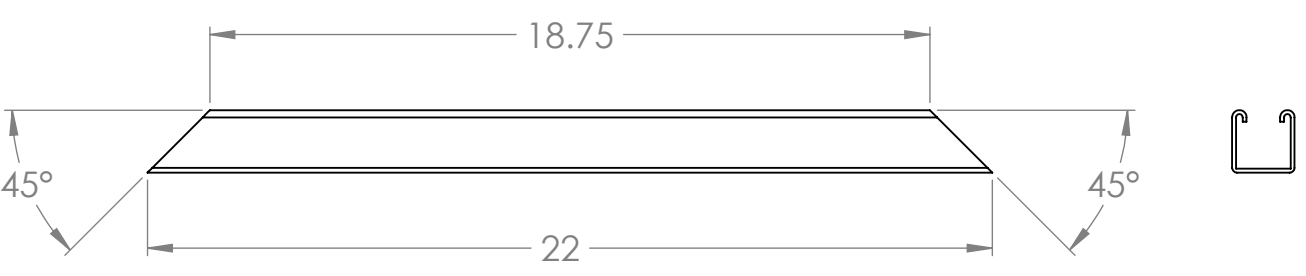
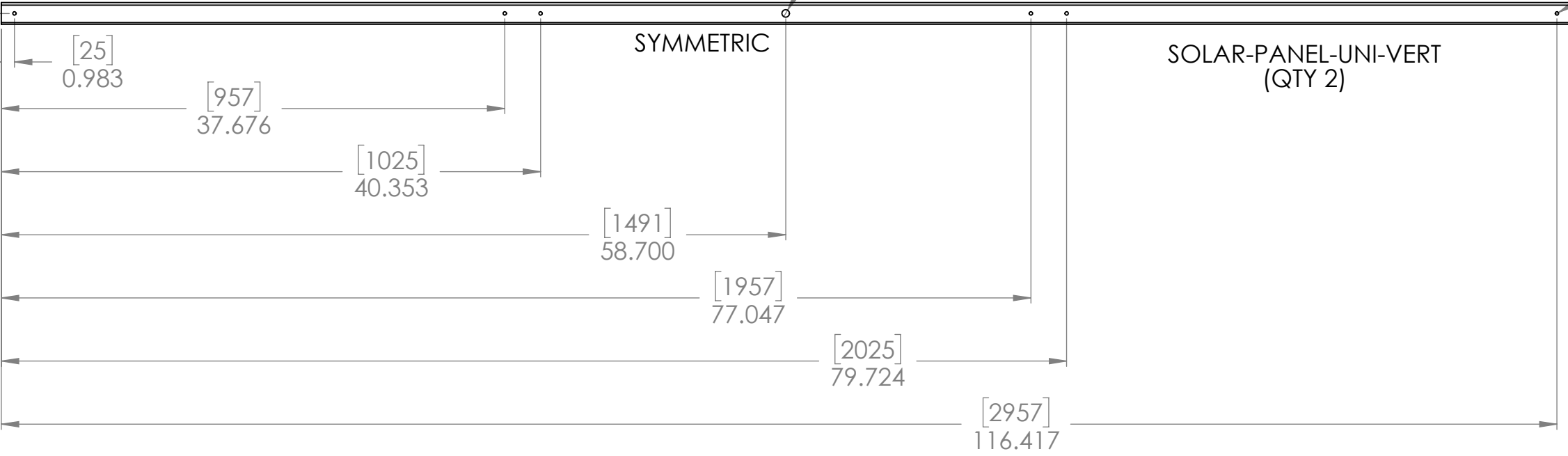
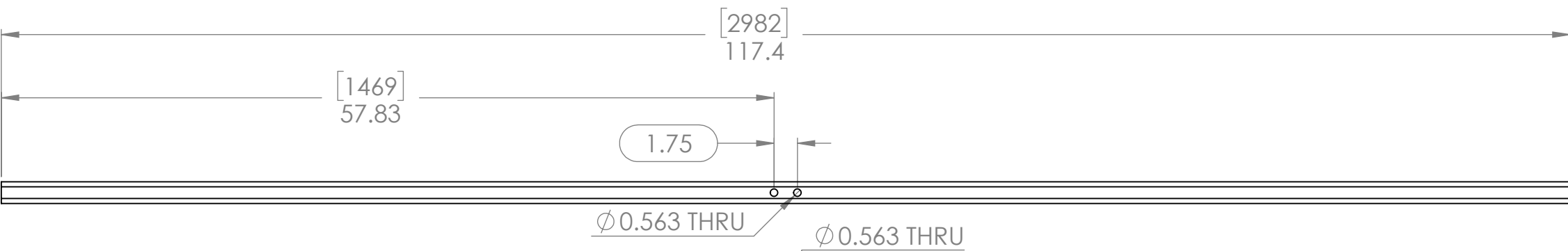
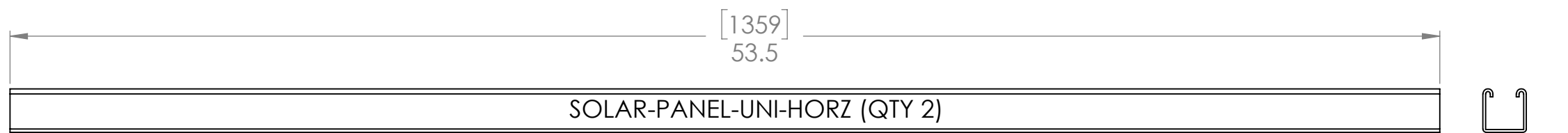

SOLAR-PANEL-UNI-BRACE (QTY 4)

UNLESS OTHERWISE SPECIFIED
 DIMENSIONS ARE IN INCHES
 TOLERANCES
 FRACTIONAL ± 1/16"
 ANGULAR BEND ± 2°



2963 Pleasant Hill Road
 Duluth, GA 30096

PROPRIETARY AND CONFIDENTIAL THE INFORMATION CONTAINED IN THIS DRAWING IS THE SOLE PROPERTY OF FORMETCO. ANY REPRODUCTION IN PART OR AS A WHOLE WITHOUT THE WRITTEN PERMISSION OF FORMETCO IS PROHIBITED.	MATERIAL UNISTRUT	CREATED	BDJ	DATE	SIZE B	DRAWING NUMBER SOLAR-PANEL	REVISION A
	MATERIAL FINISH GALVANIZED	7/18/2016 9:05:27 AM			WEIGHT:		SHEET 2 OF 5
DO NOT SCALE DRAWING	UPDATED	Wednesday, March 08, 2017 10:30:59 AM					

4

3

2

1

B

B

A

A

4

3

2

1

B

B

A

A

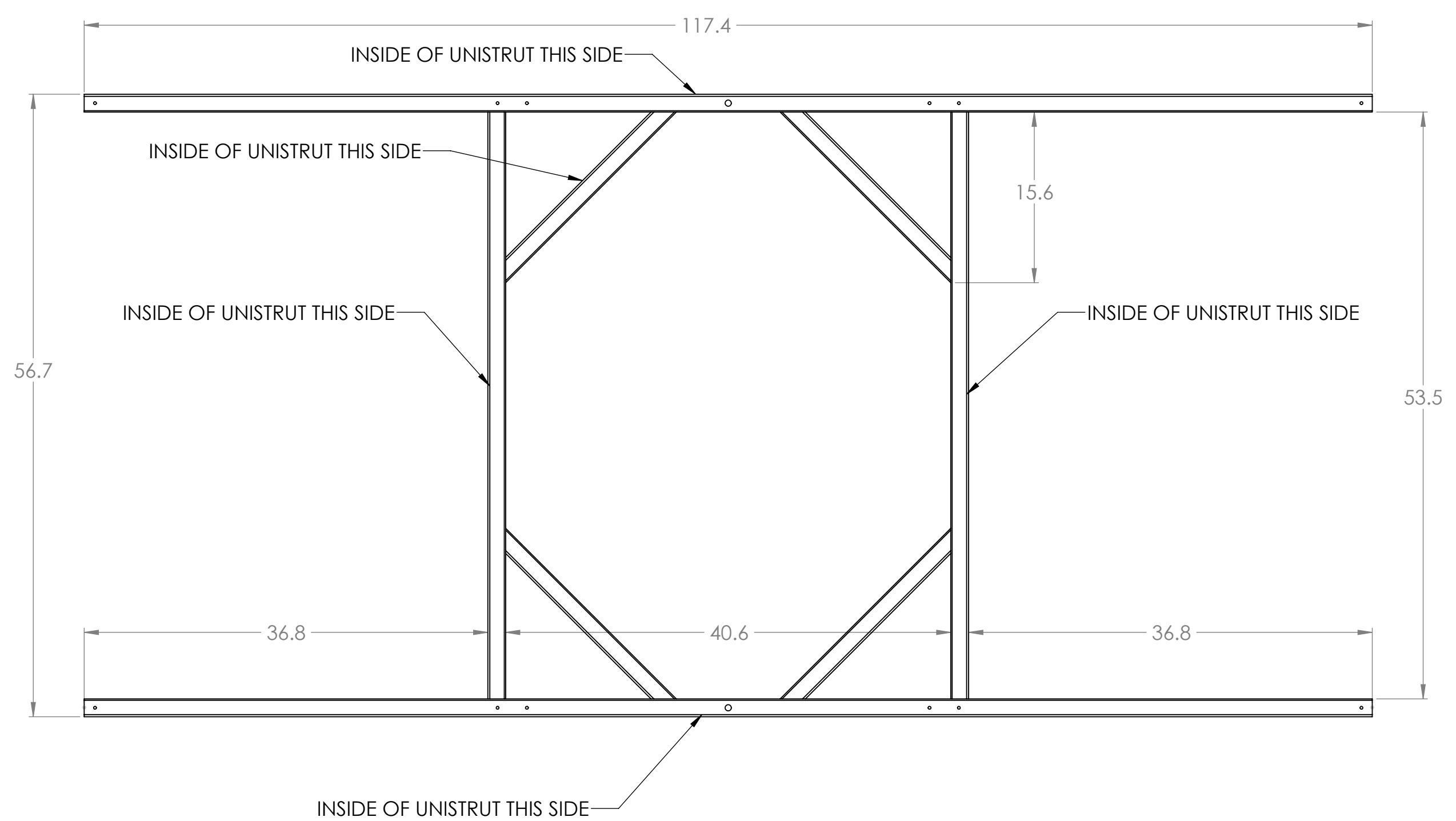

UNLESS OTHERWISE SPECIFIED
 DIMENSIONS ARE IN INCHES
 TOLERANCES
 FRACTIONAL ± 1/16"
 ANGULAR BEND ± 2°



2963 Pleasant Hill Road
 Duluth, GA 30096

PROPRIETARY AND CONFIDENTIAL THE INFORMATION CONTAINED IN THIS DRAWING IS THE SOLE PROPERTY OF FORMETCO. ANY REPRODUCTION IN PART OR AS A WHOLE WITHOUT THE WRITTEN PERMISSION OF FORMETCO IS PROHIBITED.	MATERIAL	N/A	CREATED	BDJ	DATE	SIZE	DRAWING NUMBER	REVISION
	MATERIAL FINISH	N/A	7/18/2016 9:05:27 AM			B	SOLAR-PANEL	A
DO NOT SCALE DRAWING		UPDATED	Wednesday, March 08, 2017 10:30:59 AM			WEIGHT:	SHEET 3 OF 5	

4

3

2

1

4

3

2

1

B

B

A

A

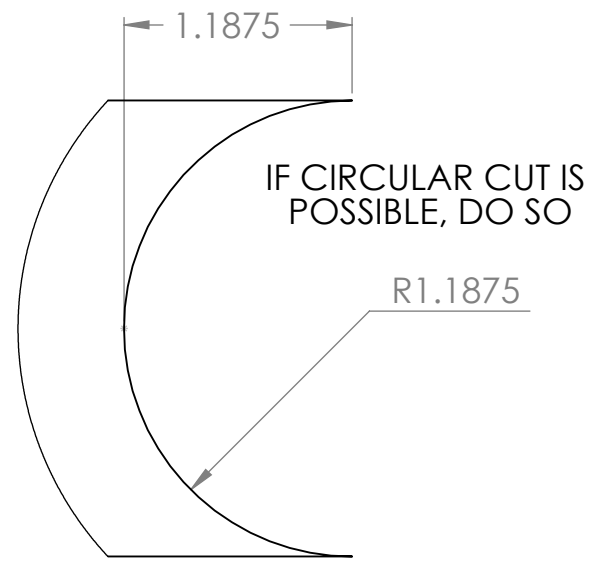
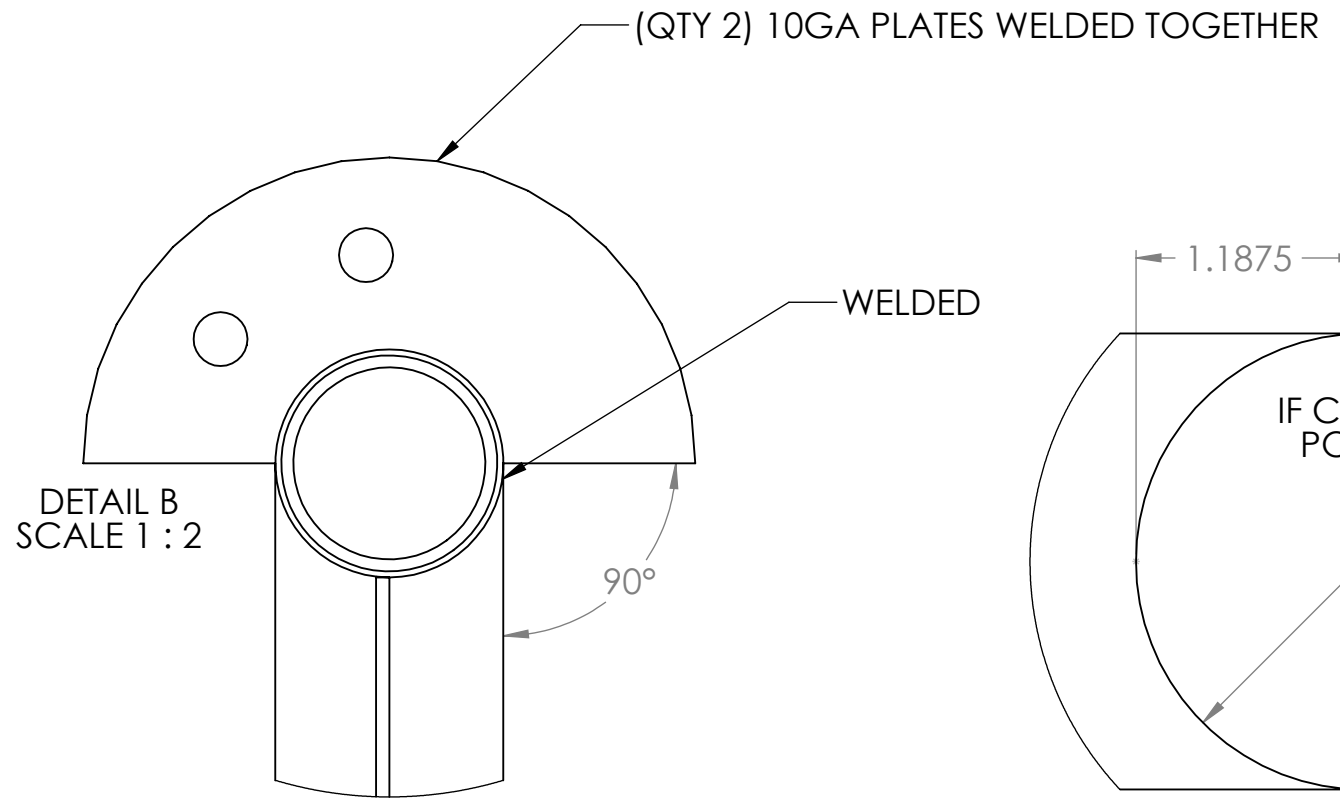
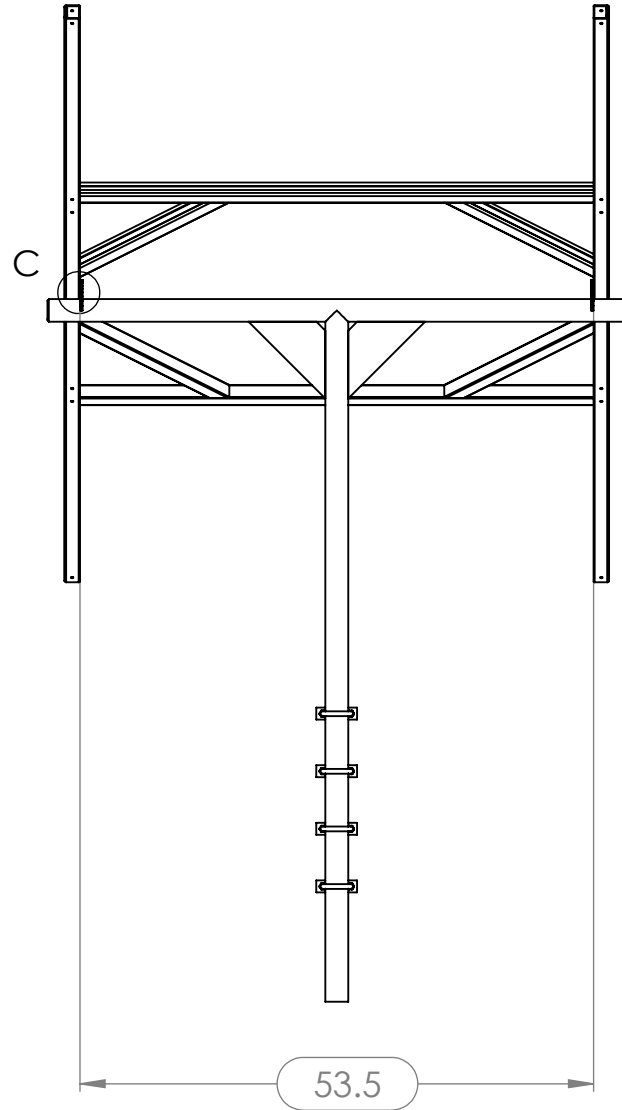
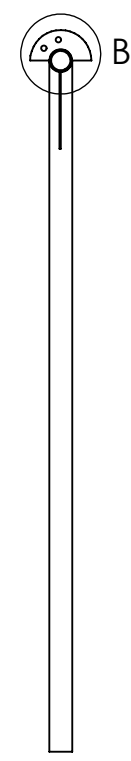

DETAIL C
SCALE 1 : 3

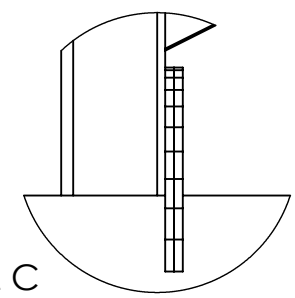

Ø 2.375

72
CUT LENGTH

PIPE2

(QTY 1) REQUIRED

UNLESS OTHERWISE SPECIFIED

DIMENSIONS ARE IN INCHES
TOLERANCES
FRACTIONAL ± 1/16"
ANGULAR BEND ± 2°



2963 Pleasant Hill Road
Duluth, GA 30096

PROPRIETARY AND CONFIDENTIAL THE INFORMATION CONTAINED IN THIS DRAWING IS THE SOLE PROPERTY OF FORMETCO. ANY REPRODUCTION IN PART OR AS A WHOLE WITHOUT THE WRITTEN PERMISSION OF FORMETCO IS PROHIBITED.	MATERIAL	CREATED	BDJ	DATE	SIZE	DRAWING NUMBER	REVISION
	STEEL TUBING	7/18/2016		9:05:27 AM	B	SOLAR-PANEL	A
	MATERIAL FINISH PAINTED	UPDATED		Wednesday, March 08, 2017 10:30:59 AM	WEIGHT:	SHEET 4 OF 5	

4

3

2

1

4

3

2

1

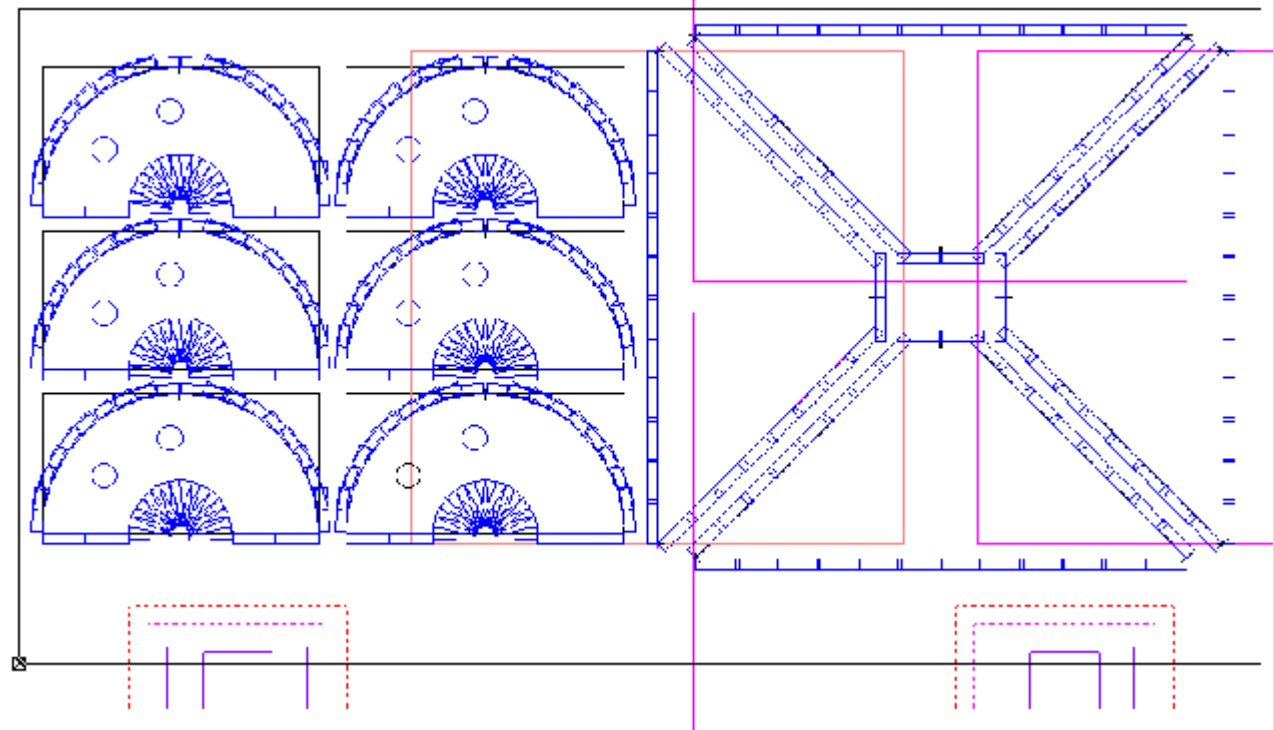
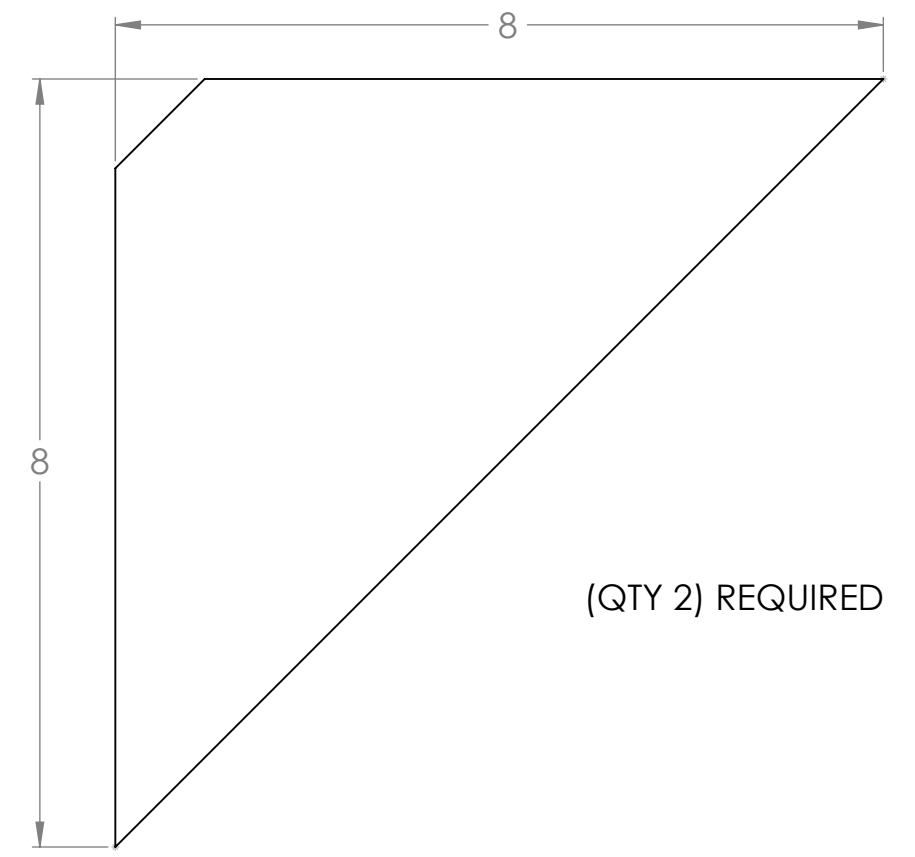
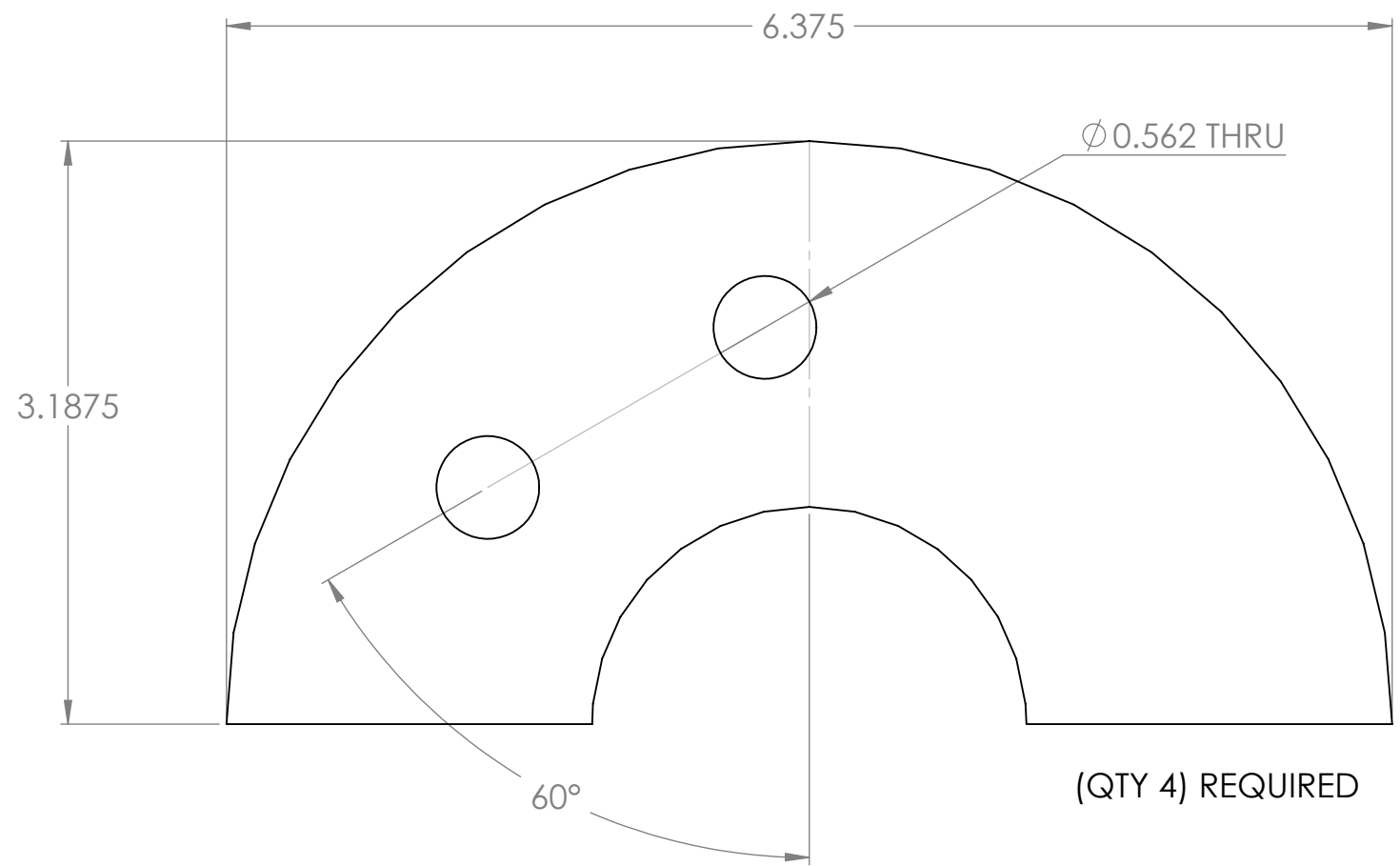

(NC FILE NAME - SOLAR-PANEL-WELDED-PLATE.nc)
 (SHEET FILE NAME - SOLAR-PANEL-WELDED-PLATE)
 (MATERIAL - 10GA GALVANNEALED STEEL)
 (THICKNESS - .138)
 (BLANK SIZE - 28.5, 15.)
 (SHEET USAGE - 48.76)
 (PART SIZE - 6.375, 3.188)
 (YIELD PER BLANK - 10 PARTS)
 (T216 RE .25 X 1. A0 360)
 (T130 RO .562 12)
 (CLAMPS - 5. 24.)
 (ESTIMATED TIME - 2 MIN. 24 SEC.)
 (PROGRAMMED BY - BRIAN J)
 (DATE - 3-8-2017)

UNLESS OTHERWISE SPECIFIED
 DIMENSIONS ARE IN INCHES
 TOLERANCES
 FRACTIONAL ± 1/16"
 ANGULAR BEND ± 2°



2963 Pleasant Hill Road
 Duluth, GA 30096

PROPRIETARY AND CONFIDENTIAL THE INFORMATION CONTAINED IN THIS DRAWING IS THE SOLE PROPERTY OF FORMETCO. ANY REPRODUCTION IN PART OR AS A WHOLE WITHOUT THE WRITTEN PERMISSION OF FORMETCO IS PROHIBITED.	MATERIAL	10GA STEEL	CREATED	BDJ	DATE	7/18/2016 9:05:27 AM	SIZE	DRAWING NUMBER	REVISION
	MATERIAL FINISH	GALVANNEALED	DO NOT SCALE DRAWING		UPDATED	Wednesday, March 08, 2017 10:30:59 AM	B	SOLAR-PANEL	A
							WEIGHT:	SHEET 5 OF 5	

4

3

2

1

B

B

A

A